

# INSTRUCTION MANUAL

## Gravity Meat Slicer

Item	13635	13637
Model	MS-IT-0330-L	MS-IT-0350-L



13635



13637

### ⚠ Warning!

Before you begin using your appliance, **PLEASE READ AND UNDERSTAND THIS DOCUMENT CAREFULLY** before installing, operating, maintaining, or servicing.

There are many important safety messages in this manual and on your appliance. Always read all safety messages.

Failure to do so can result in appliance failure, property damage, serious injury or death. Appliance failure, injury or property damage due to improper installation is not covered by warranty.

### ⛔ Stop!

**DO NOT RETURN THIS PRODUCT TO THE STORE!**

For questions or assistance with this product, call TRENTO Toll free: **1-833-487-3686** or visit the support section from our website, **www.trentoequipment.com**

Version: Revised - 06/09/2026



# Table of Contents

Models MS-IT-0330-L, MS-IT-0350-L

<b>Section</b>	<b>Page</b>
General Information -----	3 - 4
Safety and Warranty -----	4 - 6
Technical Specifications -----	7 - 9
Installation -----	9 - 11
Maintenance -----	11 - 14
Troubleshooting -----	15 - 16
Parts Breakdown -----	17 - 20
Electrical Schematics -----	21
Notes -----	22
Warranty Registration -----	23

# General Information

---

Omcan Manufacturing and Distributing Company Inc., Food Machinery of America, Inc. dba Omcan and Omcan Inc. are not responsible for any harm or injury caused due to any person's improper or negligent use of this equipment. The product shall only be operated by someone over the age of 18, of sound mind, and not under the influence of any drugs or alcohol, who has been trained in the correct operation of this machine, and is wearing authorized, proper safety clothing. Any modification to the machine voids any warranty, and may cause harm to individuals using the machine or in the vicinity of the machine while in operation.

## CHECK PACKAGE UPON ARRIVAL

Upon receipt of an Omcan shipment please inspect for external damage. If no damage is evident on the external packaging, open carton to ensure all ordered items are within the box, and there is no concealed damage to the machine. If the package has suffered rough handling, bumps or damage (visible or concealed), please note it on the bill of lading before accepting the delivery and contact Omcan within 24 hours, so we may initiate a claim with the carrier. A detailed report on the extent of the damage caused to the machine must be filled out within three days, from the delivery date shown in the shipping documents. Omcan has no recourse for damaged products that were shipped collect or third party.

**Before operating any equipment, always read and familiarize yourself with all operation and safety instructions.**

Omcan would like to thank you for purchasing this machine. It's of the utmost importance to save these instructions for future reference. Also save the original box and packaging for shipping the equipment if servicing or returning of the machine is required.

---

Omcan Fabrication et distribution Compañie Limité et Food Machinery d'Amérique, dba Omcan et Omcan Inc. ne sont pas responsables de tout dommage ou blessure causé du fait que toute personne ait utilisé cet équipement de façon irrégulière. Le produit ne doit être exploité que par quelqu'un de plus de 18 ans, saine d'esprit, et pas sous l'influence d'une drogue ou d'alcool, qui a été formé pour utiliser cette machine correctement, et est vêtu de vêtements de sécurité approprié. Toute modification de la machine annule toute garantie, et peut causer un préjudice à des personnes utilisant la machine ou des personnes à proximité de la machine pendant son fonctionnement.

## VÉRIFIEZ LE COLIS DÈS RÉCEPTION

Dès réception d'une expédition d'Omcan veuillez inspecter pour dommages externes. Si aucun dommage n'est visible sur l'emballage externe, ouvrez le carton afin de s'assurer que tous les éléments commandés sont dans la boîte, et il n'y a aucun dommage dissimulé à la machine. Si le colis n'a subi aucune mauvaises manipulations, de bosses ou de dommages (visible ou cachée), notez-le sur le bond de livraison avant d'accepter la livraison et contactez Omcan dans les 24 heures qui suivent, pour que nous puissions engager une réclamation auprès du transporteur. Un rapport détaillé sur l'étendue des dommages causés à la machine doit être rempli dans un délai de trois jours, à compter de la date de livraison indiquée dans les documents d'expédition. Omcan n'a aucun droit de recours pour les produits endommagés qui ont été expédiés ou cueilli par un tiers transporteur.

# General Information

---

Avant d'utiliser n'importe quel équipement, toujours lire et vous familiariser avec toutes les opérations et les consignes de sécurité.

Omcan voudrais vous remercier d'avoir choisi cette machine. Il est primordial de conserver ces instructions pour une référence ultérieure. Également conservez la boîte originale et l'emballage pour l'expédition de l'équipement si l'entretien ou le retour de la machine est nécessaire.

Omcan Empresa De Fabricacion Y Distribucion Inc. Y Maquinaria De Alimentos De America, Inc. dba Omcan y Omcan Inc. no son responsables de ningun daño o perjuicio causado por cualquier persona inadecuada o el uso descuidado de este equipo. El producto solo podra ser operado por una persona mayor de 18 años, en su sano juicio y no bajo alguna influencia de droga o alcohol, y que este ha sido entrenado en el correcto funcionamiento de esta máquina, y ésta usando ropa apropiada y autorizada. Cualquier modificación a la máquina anula la garantía y puede causar daños a las personas usando la máquina mientras esta en el funcionamiento.

## REVISE EL PAQUETE A SU LLEGADA

Tras la recepcion de un envio Omcan favor inspeccionar daños externos. Si no hay daños evidentes en el empaque exterior, Habra el carton para asegurarse que todos los articulos solicitados estén dentro de la caja y no encuentre daños ocultos en la máquina. Si el paquete ha sufrido un manejo de poco cuidado, golpes o daños (visible o oculto) por favor anote en la factura antes de aceptar la entrega y contacte Omcan dentro de las 24 horas, de modo que podamos iniciar una reclamación con la compañía. Un informe detallado sobre los daños causados a la máquina debe ser llenado en el plazo de tres días, desde la fecha de entrega que se muestra en los documentos de envío. Omcan no tiene ningun recurso por productos dañados que se enviaron a recoger por terceros.

Antes de utilizar cualquier equipo, siempre lea y familiarizarse con todas las instrucciones de funcionamiento y seguridad.

Omcan le gustaría darle las gracias por la compra de esta máquina. Es de la mayor importancia para salvar estas instrucciones para futuras consultas. Además, guarda la caja original y el embalaje para el envío del equipo si servicio técnico o devolución de la máquina que se requiere.

# Safety and Warranty

---

## LIMITS OF USE – SAFETY NORMS

These machine were designed and built to slice foodstuff in compliance to the norms of the CE 2006/95/EEC, 93/68/EEC, 2006/42/EEC, 2002/72/EEC, 2004/108 CE, REG 1935/2004/EEC, 2002/95/CE (RoHS) and to the following regulations EN1974, EN ISO12100-1, EN ISO12100-2, EN 294, EN60204-1, EN60335-1, EN60335-2-64.

# Safety and Warranty

---

## GENERAL SAFETY REGULATIONS

The slicers must be used only by suitably trained personnel. Furthermore, this personnel must have read this manual carefully. In particular, please comply to the following instructions:

- Install the machine according to the instructions contained in the “installation” section.
- Do not modify nor exclude the mechanical and electrical safety devices.
- Do not use the machine with improvised connections, or provisional or non insulated cables.
- Check the power cable and gland plate on the machine body regularly and when necessary have them replaced by qualified personnel.
- In case of anomalies, defective operation, incorrect movement, unusual noise, etc stop the machine immediately.
- Before cleaning or servicing, disconnect the machine from the mains.
- Always use scratch-proof and non-slip gloves during cleaning or maintenance.
- Lay or remove the goods to be sliced on the sliding plate only when the latter is completely pushed back and the thickness control knob positioned to 0.
- To move the carriage tray when slicing, use the handle or the product grip handle.
- For extraordinary maintenance (to replace the sharpener wheels, the blade, or others) please contact the manufacturer or qualified and duly authorized personnel.
- Avoid running the slicers with no product on it.
- The slicers are equipped with a ventilated motor. Extended continual use is not recommended. Let the motor cool down after 30 minutes of use.

**RESIDENTIAL USERS: vendor assumes no liability for parts or labor coverage for component failure or other damages resulting from installation in non-commercial or residential applications. The right is reserved to deny shipment for residential usage; if this occurs, you will be notified as soon as possible.**

## 1 YEAR PARTS AND LABOR BENCH WARRANTY

Within the warranty period, contact Omcan Inc. at 1-800-465-0234 to schedule a drop off to either an Omcan authorized service depot in the area, or to an Omcan Service warehouse to repair the equipment.

Unauthorized maintenance will void the warranty. Warranty covers electrical and part failures, not improper use.

Please see <https://omcan.com/disclaimer> for complete info.

## MANUFACTURER’S WARRANTY AND LIABILITY

The manufacturer’s warranty covering the good functioning of the machines and their compliance to the service for which they have been designed depends on the correct application of the instructions contained in this manual. The Manufacturer assumes no liability either direct or indirect deriving from:

- Failure to comply with the instructions contained in this manual.

# Safety and Warranty

---

- Use of the machine by personnel who has not read or fully understood the content of this manual.
- Use not complying to the specific norms currently applicable in the country of installation.
- Unauthorized modifications and/or repairs.
- Use of non original accessories or spare parts.
- Exceptional events.

## ENVIRONMENTAL CONDITIONS OF USE

Temperature: from -5°C and + 40°C.

Relative humidity: max 95%.

## OPENING THE BOX

On reception check packaging integrity, otherwise inform the forwarding agent or the area agent immediately.

To unpack the machine, proceed as follows:

- Open the box and remove your copy of the manual of use and maintenance, then proceed according to the instructions found on that manual.
- Lift the machine still wrapped in a transparent polyethylene sheet and extract it from the box.
- Now check the box content and make sure it corresponds to what shown on the external label.

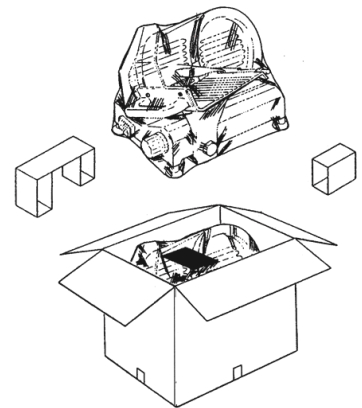

## WARNING:

The packaging components (cardboard, polyethylene, and others) are classified as normal solid urban waste and can therefore be disposed of without difficulty.

**In any case, for suitable recycling, we suggest disposing of the products separately (differentiated waste) according to the current norms.**

**DO NOT DISCARD ANY PACKAGING MATERIALS IN THE ENVIRONMENT!**

# Technical Specifications

Model	MS-IT-0330-L	MS-IT-0350-L
Blade Size	13" / 330mm	14" / 350mm
Cut Thickness Range	0" - 0.6" / 0 - 16mm	
Cutting Size	11.3" x 9.8" 286 x 250mm	12.8" x 10.3" 324 x 260mm
Power	0.5 HP / 0.37 kW	
Cheese Slicing*		
Slicing Volume*	2 hours	
RPM	280	286
Electrical	110-120V / 60Hz / 1	
Weight	85 lbs. / 38.6 kgs.	97 lbs. / 44.1 kgs.
Packaging Weight	86 lbs. / 39.1 kg.	104 lbs. / 47.3 kgs.
Dimensions	30.3" x 21.7" x 18.3" 770 x 550 x 465mm	22.8" x 23" x 19" 580 x 584 x 483mm
Packaging Dimensions	28" x 25" x 21" 711 x 635 x 533mm	29" x 32" x 22" 737 x 822 x 559mm
Item Number	13635	13637

\*Results may vary due to product consistency and temperature.

The machine is essentially made of a base supporting a circular blade mounted in a tilted position. This blade is driven by an electrical motor to slice foodstuffs. The machine is equipped with a carriage holding a product tray and sliding on a bar mounted under the base top, parallel to the blade. Slice thickness is adjusted by means of a gauge plate mounted in front of the blade. This plate, against which rests the product to be sliced is moved transversely with respect to the blade by a value corresponding to the desired slice thickness. The product is fed to the machine (towards the gauge plate) by gravity. All the machine components are made of polished and anodically oxidized aluminium alloy, of stainless steel and food grade plastic material. The blade is driven by an electrical motor, transmission is by means of a longitudinally grooved belt. The machine is started and stopped by a control button or switch provided with auxiliary circuit preventing accidental restarts after an outage. Some of the machine models have a user-friendly and safe built-in blade sharpener.

## ELECTRICAL SAFETY DEVICE

- Optional safety micro-switch preventing the motor from starting when the blade guard is removed.

## WARNING: RESIDUAL RISKS

Notwithstanding all the possible cautions taken during the design and the construction of the machine, residual risks (cutting) still exist during use or during cleaning or maintenance. Therefore be careful and **PAY THE UTMOST ATTENTION** to what you are doing. **DO NOT** use the machine if you are not in perfect psychological and physical conditions. **DO NOT ALLOW** anyone near the machine when it is in use. **ALWAYS** wear gloves that can resist cuts or tears when cleaning, lubricating or sharpening

# *Technical Specifications*

---

the blade. Slice only the products mentioned as sliceable. NEVER try to slice products that have been mentioned as non sliceable.

## **ACCESSORIES**

If not otherwise defined at the moment of order, the machines are supplied together with the following:

- Instructions manual for installation, use and maintenance.

## **PRODUCTS THAT CAN BE SLICED**

- All types of cold cuts (raw, cooked, smoked).
- Meat without bone (raw or cooked, at a temperature not less than + 3°C).
- Vegetables (all types).

## **PRODUCTS THAT MUST NOT BE SLICED:**

- Frozen or deep-frozen food.
- Food containing bones (meat or fish).
- Any other non-food product.
- Cheese.

# Technical Specifications

## MAIN COMPONENTS

- |                                  |   |                             |
|----------------------------------|---|-----------------------------|
| 1. Switch.                       | 7. Product tray.  | 13. Pusher plate extension. |
| 2. N/A.                          | 8. Blade plate.   | 14. N/A.                    |
| 3. Slice thickness control knob. | 9. Product grip.  | 15. Blade plate tie-rod.    |
| 4. Adjustable foot.              | 10. Blade.  | 16. Supply cord.            |
| 5. Carriage tray support.        | 11. Product grip handle.  | 17. Gauge plate.            |
| 6. Base.                         | 12. Manufacturer identification plate, machine data and UE marks. | 18. Sharpener.              |

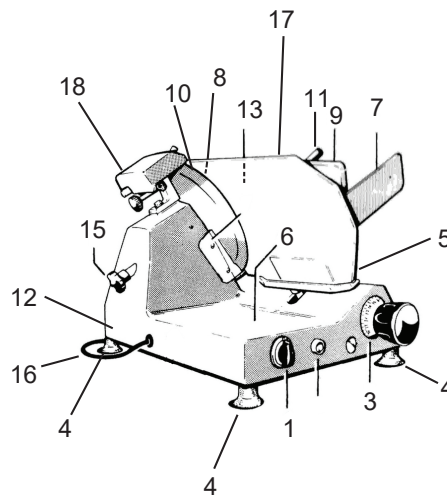

*Illustrations may differ from actual machines.*

## Installation

### INSTALLING THE MACHINE

Position the machine on a well leveled, smooth and dry top suitably dimensioned to withstand the machine weight.

### ELECTRICAL CONNECTION

Install the machine near a compliant outlet derived from a system meeting the local norms.

# Installation

---

**The user is responsible for** ascertaining that the electrical system is suitably dimensioned and functions correctly (supply line, outlet, distribution panel, differential protecting breaker, grounding).

**Before carrying out the connection** ascertain that the mains characteristics correspondent to those indicated on the machine plate.

## COMMANDS

### START AND STOP BUTTONS / SWITCHES

- Turn switch or press the white or green button (1) to start running the blade.
- The light turns on to indicate that the machine works correctly.
- Turn switch or press the red or black button to stop the blade.

Slice thickness can be adjusted by turning the graduated knob (4) counterclockwise.

**Thickness adjustment range:** see paragraph “technical description and conditions of use”.

### FUNCTIONING TEST AND BLADE ROTATION DIRECTION

Start the machine and check whether the light is on; make sure that the blade rotates in the direction indicated by the arrow (counterclockwise if you look at the machine from the blade plate side).

- Ascertain that the carriage and the product grip slide correctly.
- Ascertain that the gauge plate works and adjust thickness to desired value.

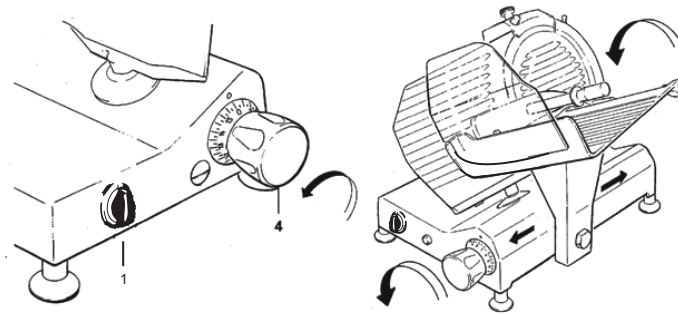

## USING THE MACHINE

### LOADING THE PRODUCT ON THE TRAY AND SLICING

- Ascertain that the thickness control knob is correctly positioned to '0'.
- Draw back the carriage completely (towards the operator) to loading position.
- Lift the product grip by pulling it away by 10 cm from the blade and put it in rest position.
- Lay the product to be sliced against the guide plate on the operator side.
- Secure by means of the product grip by exerting a slight pressure.

# Installation

---

- Adjust the thickness gauge. Start the blade by turning the switch or by pressing on the white or green button.
- Grip the handle affixed onto the plate and start the forward and backward cutting movement. The product travels towards the guide plate by gravity.
- When the product weight or its dimensions do not provide a satisfactory cut by effect of the gravity, use the product grip handle.
- When finished, return the thickness control knob to '0' and draw the carriage back.
- Stop the blade by pressing the black or red button.

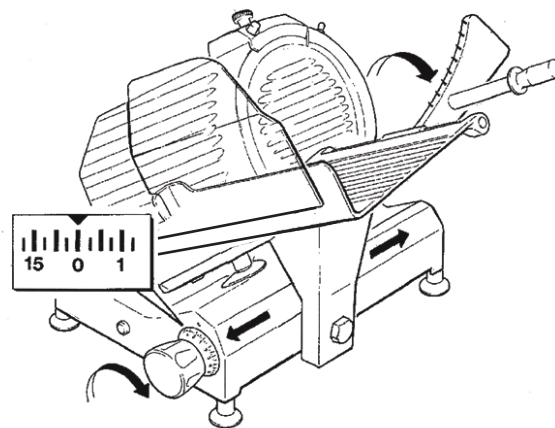

# Maintenance

---

## CLEANING THE SLICER

### GENERAL

The machine must always be accurately cleaned **at least once a day**, and more often if necessary. **Always use protective gloves.**

### DISASSEMBLING THE MACHINE FOR CLEANING

- Disconnect the plug from the mains.
- Turn the gauge plate knob to '0'.
- Remove the various components as described in the following paragraphs.
- Unscrew (counterclockwise) the blade guard tie-rod.
- If the blade guard is blocked, press on the rod knob to move it a little.
- Extract the rod and remove the blade guard using for this operation only the side knobs.
- Loosen and remove the two fixing screws with knurled head.
- Remove the slice guard.

# Maintenance

---

To clean the machine body and the blade use only a cloth damped with water and biodegradable lathery detergent having 7-8 pH and at a temperature not below + 30°C. Do not clean the machine by using water or vapor sprays or similar systems.

## WARNING:

Use scratch-proof and non-slip gloves to carry out the following operations. Proceed carefully and pay attention to what you are doing. **DANGER OF CUTTING!**

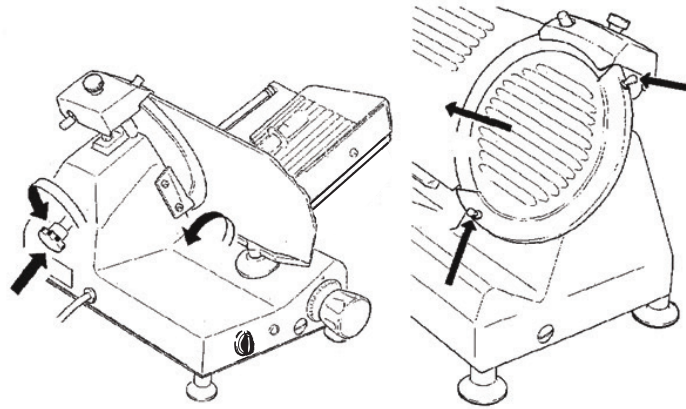

## REASSEMBLING THE MACHINE

Proceed as indicated for the previous operations but in reverse order.

## GENERAL MAINTENANCE

The operator is allowed to perform the following maintenance operations:

- **Blade sharpening:** regularly (intervals and duration obviously depend on the use of the machine, time of use and type of product sliced).
- **Lubrication of carriage sliding guides:** once a week.
- **Lubrication of product grip sliding bar:** once a week.
- **Adjustment of motor belt tension:** as required.
- **Checking the power supply cord conditions and of the gland plate:** from time to time.

## WARNING

Maintenance must always be carried out when the **machine is disconnected from the mains** and if no other position is specifically required, with the thickness control knob on '0'.

The following maintenance operations are to be entrusted only to **personnel authorized by the manufacturer:**

- Replacing the blade.

# Maintenance

- Replacing the sharpener stones.
- Replacing the motor transmission belt.
- Replacing electrical system components under the machine base.
- Repairing structural parts, repairing the components under the base.

## BLADE SHARPENING

Before proceeding, clean the machine accurately as explained in the previous paragraphs.

### WARNING

Sharpening can be done only up to 12 mm of the blade diameter value. **Beyond this value, the BLADE MUST BE REPLACED ONLY by personnel AUTHORIZED BY THE MANUFACTURER.**

### SHARPENING VERSIONS WITH BUILT-IN SHARPENER

To sharpen the blade periodically as soon as the cutting capacity decreases. Please proceed as per the following instructions:

1. After disconnecting from the mains, clean the blade accurately using denaturized alcohol to degrease it.
  2. Loosen the knob (1) and turn the sharpener (2) by 180° and insert the wheels on the slicer blade. Re lock the knob (1).
  3. Operate the switch (3) and press the button (4).
  4. Allow the blade to rotate for about 30 to 40 seconds then use the switch (3) to stop it. Brush a pencil lightly on the external side of the blade to check for a slight spud.
- We advise performing this operation with the utmost care as the blade is extremely sharp.**
5. If some spud is found, operate the switch (3) again for 3 to 4 seconds by pressing the buttons 4 and 5 at the same time.

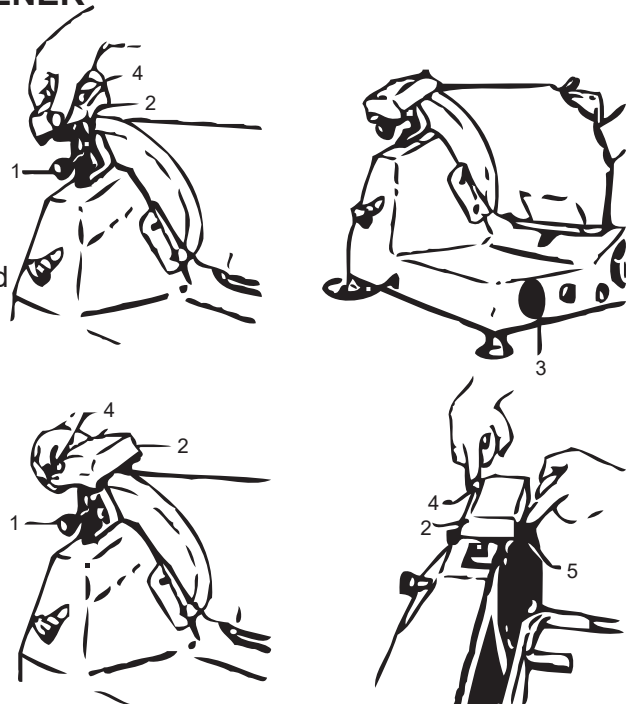

**DO NOT PROLONG THIS OPERATION BEYOND THE FEW SECONDS MENTIONED OTHERWISE THE BLADE EDGE WILL WARP.**

6. After completing sharpening, we advise cleaning the wheels using a small brush and alcohol.
7. Now return the sharpener to its original position.

### LUBRICATION

**Carriage sliding guides product grip (once a week)**

*Use the Omcan oil #27336, otherwise use white Vaseline oil. DO NOT USE VEGETABLE OILS.*

# Maintenance

---

- Spread a small quantity of oil on the bar and move the assembly 3 or 4 times. Clean as required to remove excess of oil.

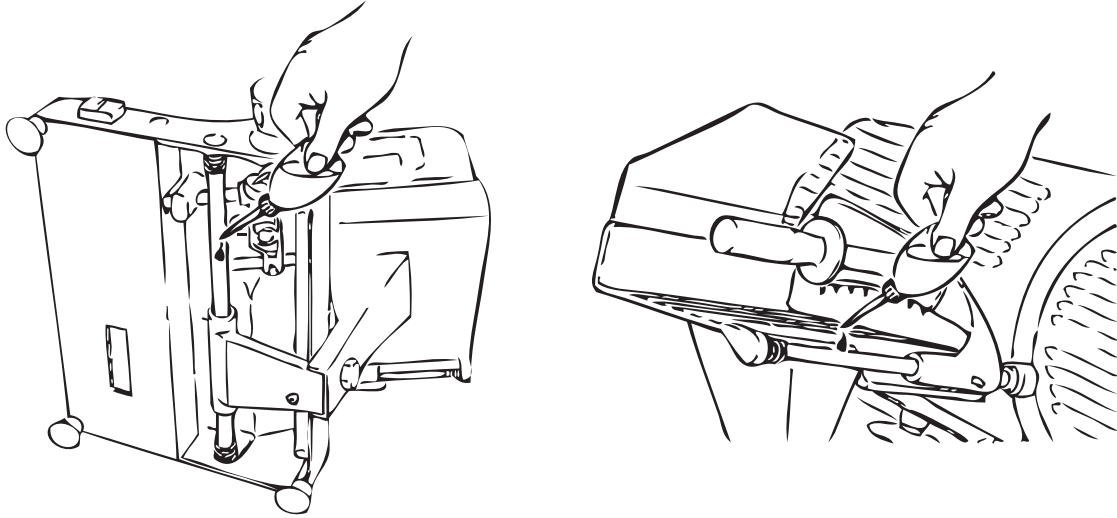

## ADJUSTING THE MOTOR BELT TENSION

After a given period of service an unusual noise may occur because of the belt bedding. In this case, tighten the belt-stretcher on the side of the motor under the machine base.

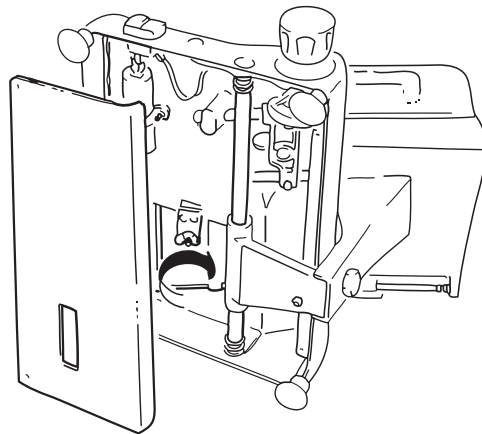

# Troubleshooting

The table below indicates the most common problems that may arise during slicing and the necessary remedies.

PROBLEM	POSSIBLE CAUSE	REMEDY
The machine does not start when the white or green button is pressed.	No power supply.	Ascertain that the plug is correctly inserted.
	The blade guard is not correctly positioned.	Check.
	Defective electrical control circuit.	Call technical assistance.
When the switch is turned or when the white or green button is pressed, the machine starts, but the white functioning light is not on.	Defective indicator.	Do not use the machine when the pilot lamp is not on; call technical assistance.
The machine starts, but there are vibrations. The motor is very hot and there is a bad smell.	Defective motor or transmission.	Do not use the machine, call technical assistance.
Under strain, the machine slows down or comes to a stop.	Defective transmission.	Call technical assistance.
Excessive resistance to product slicing.	The blade is blunt.	Sharpen the blade.
The slices are ragged and/or shaped irregularly.	The blade is blunt.	Sharpen the blade.
	The blade is excessively worn out.	Call technical assistance.
Unsatisfactory blade sharpening.	Worn wheels.	Replace the wheels; call technical assistance.
The product tray does not slide.	Guides are insufficiently lubricated.	Lubricate.
When the switch is turned or when the black or red button is pressed, the machine does not stop.	Defective electrical control circuit.	Stop the machine, unplug from mains and call technical assistance.

## DISMANTLING THE SLICER

These machines are made of the following elements:

- Aluminium frame.
- Stainless steel fittings and others.
- Electrical parts and cords.
- Electrical motor.
- Plastic materials, etc.

Whether dismantling is entrusted to third parties or done in-house (in that last case you will have to separate the various materials) please note that disposal of the materials can only be carried out by duly authorized businesses. In any case, please comply to the current norms of your country.

# Troubleshooting

---

## WARNING

In any case, to remove the blade and dispose of it, you must contact the manufacturer or personnel duly authorized by the manufacturer. **NEVER DISPOSE OF WASTE IN AREAS WHERE ACCESS IS NOT DELIMITED BY BARRIERS AND FORBIDDEN BY WARNING SIGNS AS THIS WASTE REPRESENTS A SERIOUS DANGER, ESPECIALLY FOR CHILDREN AND ANIMALS. ANY RESPONSIBILITY ARISING OUT OF INCORRECT DISPOSAL FALLS ON THE OWNER.**

## Guide to the treatment of waste equipment

This product complied with Directive 2002/96 /EC.



The crossed out wheeled bin symbol on equipment or its packaging indicates that at the end of its working life the equipment should not be treated as general household waste but taken to one of the recycling centres for electrical and electronic equipment run by local authorities. Alternatively, it may be handed over to the reseller when purchasing new equipment of the same type. The user is responsible for consigning the equipment to appropriate collection facilities at the end of its working life or face the penalties provided for by current waste management legislation. Separate collection for subsequent delivery of waste equipment to environmentally-compatible recycling, treatment and disposal facilities to prevent possible negative impacts on the environment and human health whilst encouraging recycling of the product's components. For further information regarding the available collection facilities, please contact your local refuse collection service or the dealer from whom the purchase was made. The manufacturer and/or importer fulfil their obligations concerning environmentally-compatible recycling, treatment and disposal either individually or by joining a collective scheme.

***For parts or service call 1-800-465-0234.***

# Parts Breakdown

**Model MS-IT-0330-L 13635**

Sold Complete

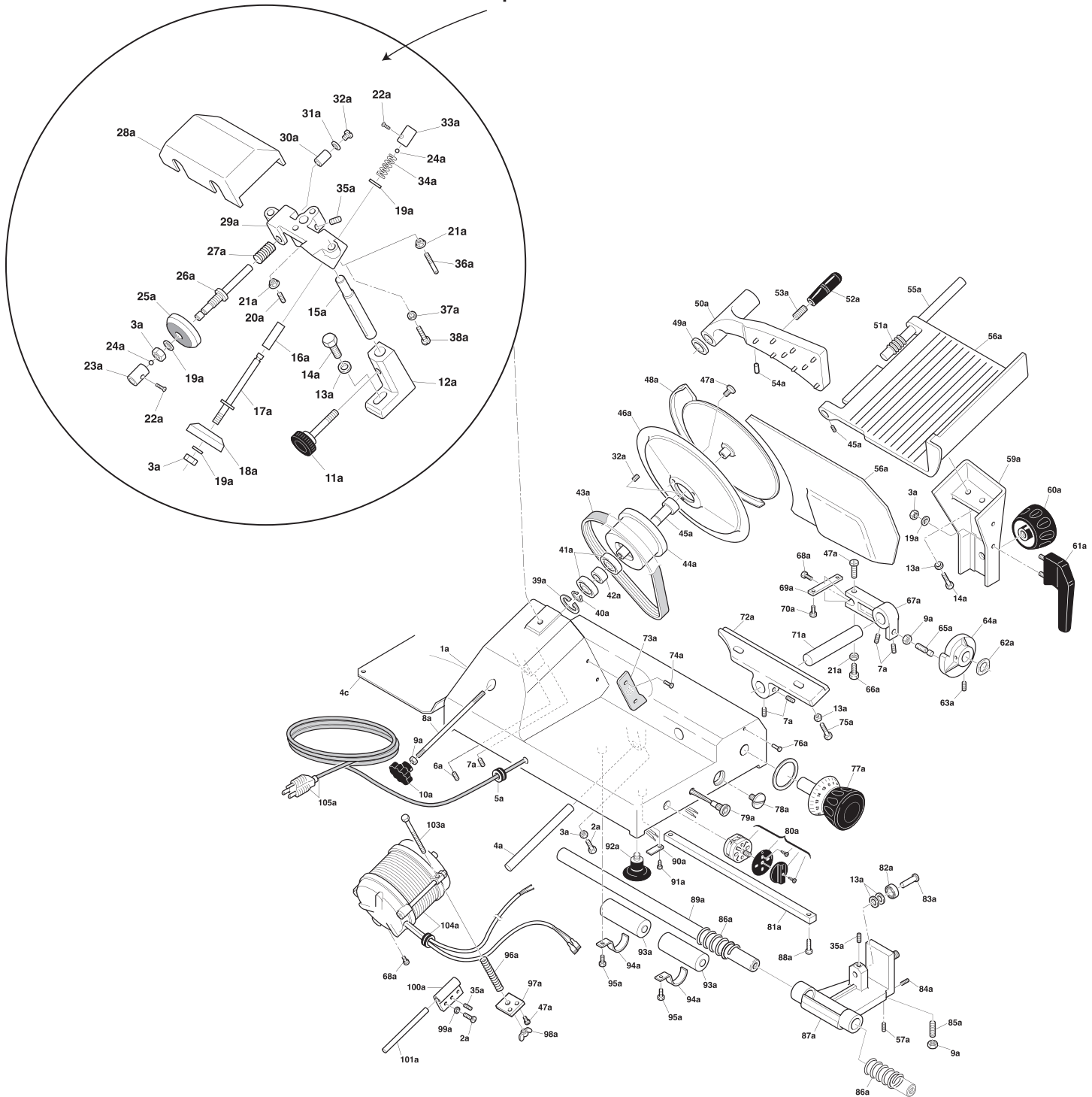

# Parts Breakdown

## Model MS-IT-0330-L 13635

Item No.	Description	Position	Item No.	Description	Position	Item No.	Description	Position
34636	Housing for 13635	A1	34671	Washer for 13635	A37	34706	Meat Deflector for 13635	A73
34637	Screw for 13635	A2	34672	Screw TC for 13635	A38	34707	Screw for 13635	A74
34638	Nut for 13635	A3	34673	Clip for 13635	A39	34708	Screw TE for 13635	A75
34639	Guide Plate Pin for 13635	A4	34674	Clip for 13635	A40	34709	Copper Rivet for 13635	A76
34640	Strain Relief for 13635	A5	34675	Bearing for 13635	A41	34710	Index Knob for 13635	A77
34641	Set Screw for 13635	A6	34676	Spacer for 13635	A42	34711	Screw Chrome for 13635	A78
34642	Set Screw for 13635	A7	15179	Belt TB2-360x12 for 13635	A43	34712	Light for 13635	A79
15202	Tie Rod for 13635	A8	34678	Spindle Pulley for 13635	A44	34713	Switch - On / Off for 13635	A80
34643	Nut for 13635	A9	34679	Bearing Shaft for 13635	A45	34714	Carriage Rail for 13635	A81
34644	Tie Rod Handle for 13635	A10	44857	Blade 330 40-3-270 for 13635	A46	34715	Bearing for 13635	A82
34645	Sharpener Tie Rod for 13635	A11	34681	Screw TPSV for 13635	A47	34716	Pin for 13635	A83
34646	Sharpener Support Bracket for 13635	A12	19284	Blade Shield for 13635	A48	34717	Set Screw for 13635	A84
34647	Washer for 13635	A13	34682	Rubber Washer for 13635	A49	34718	Set Screw PVC for 13635	A85
34648	Screw TE for 13635	A14	34683	Meat Grip for 13635	A50	34719	Slide Bar Spring for 13635	A86
34649	Sharpener Support Shaft for 13635	A15	34684	Meat Carriage Shaft Spring for 13635	A51	34720	Carriage Support for 13635	A87
34650	Sharpener Pin Spacer for 13635	A16	27887	Meat Grip Handle for 13635	A52	34721	Screw TC for 13635	A88
34651	Sharpener Pin for 13635	A17	34685	Meat Grip Handle Screw for 13635	A53	34722	Carriage Slide Bar for 13635	A89
33553	Finishing Stone for 13635	A18	34686	Plastic Dowel for 13635	A54	34723	Stop Plate for 13635	A90
34653	Washer for 13635	A19	34687	Meat Carriage Shaft for 13635	A55	34724	Tapping Screw for 13635	A91
34654	Set Screw for 13635	A20	34688	Meat Carriage for 13635	A56	34725	Foot for 13635	A92
34655	Nut for 13635	A21	34689	Set Screw for 13635	A57	34726	Capacitor for 13635	A93
34656	Screw TGS for 13635	A22	34690	Guide Plate for 13635	A58	34727	Capacitor Clamp for 13635	A94
34657	Sharpener Push Button for 13635	A23	34691	Meat Carriage Support for 13635	A59	34728	Screw TC for 13635	A95
34658	Ball Bearing for 13635	A24	27886	Knob for 13635	A60	34729	Motor Spring for 13635	A96
33032	45x9x6 Sharpening Stone for 13635	A25	34693	Meat Carriage Handle for 13635	A61	34730	Motor Bracket for 13635	A97
34660	Sharpener Pin for 13635	A26	34694	Wavy Washer for 13635	A62	34731	Wing Nut for 13635	A98
34661	Sharpener Pin Spring for 13635	A27	34695	Set Screw for 13635	A63	34732	Washer for 13635	A99
34662	Sharpener Cover for 13635	A28	34696	Cam for 13635	A64	34733	Hinge for 13635	A100
34663	Sharpener Body for 13635	A29	34697	Cam Screw for 13635	A65	34734	Motor Support Shaft for 13635	A101
34664	Sharpener Pin Spacer for 13635	A30	34698	Screw for 13635	A66	15203	Motor Tie Rod for 13635	A103
34665	Washer for 13635	A31	34699	Cam Guide for 13635	A67	34735	Motor for 13635	A104
34666	Screw TC for 13635	A32	34701	Screw TC for 13635	A68	14859	Power Cord for 13635	A105
34667	Sharpener Push Button for 13635	A33	34702	Cam Plate for 13635	A69	37449	Bottom Cover for 13635	C4
34668	Sharpener Pin Spring for 13635	A34	34703	Screw TC for 13635	A70	15187	Carriage Knob for 13635	
34669	Set Screw for 13635	A35	34704	Guide Plate Pin for 13635	A71	27539	Complete Sharpening Assy. for 13635	
34670	Stud Screw for 13635	A36	34705	Guide Plate Support for 13635	A72			

# Parts Breakdown

**Model MS-IT-0350-L 13637**

Sold Complete

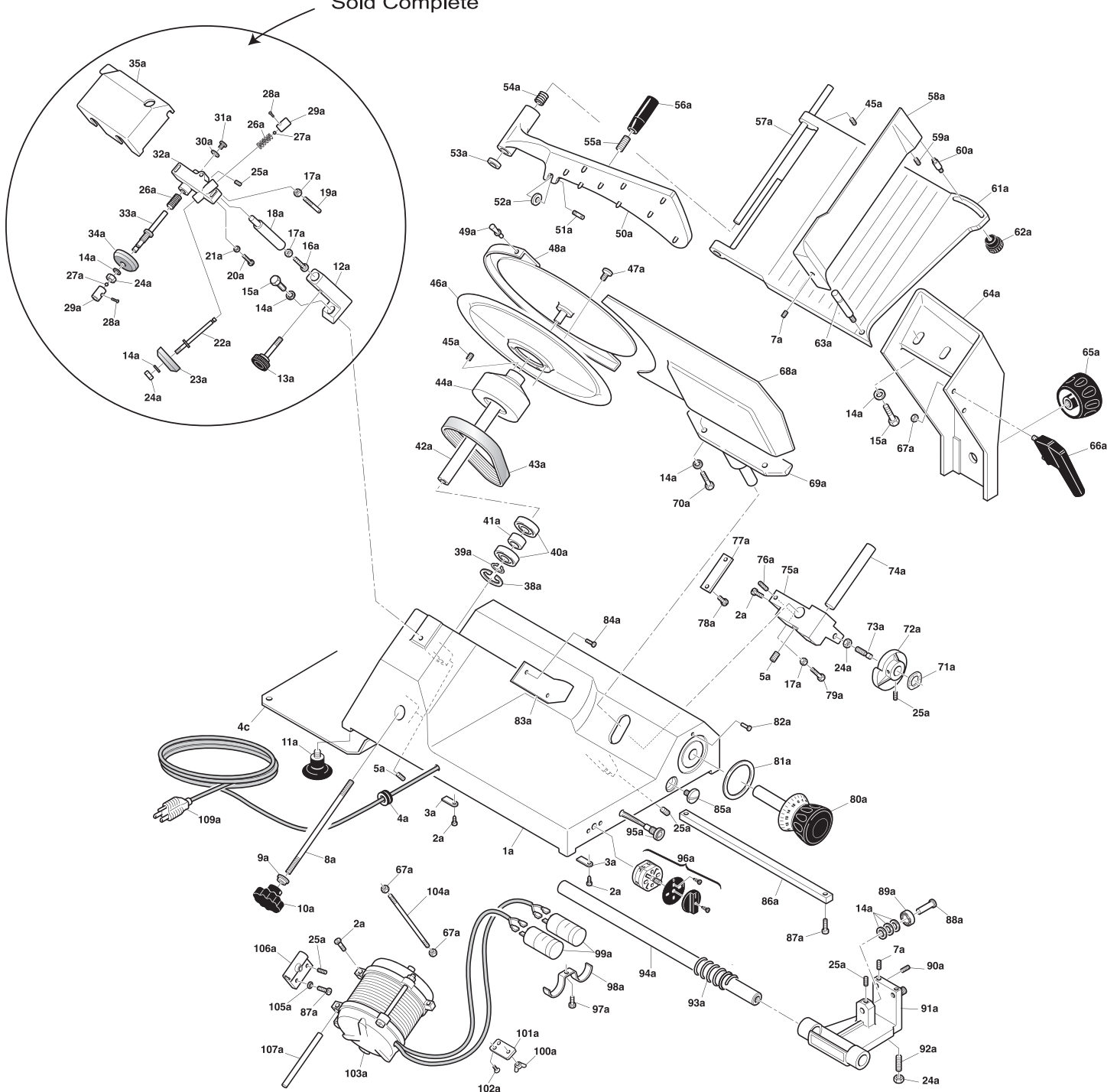

# Parts Breakdown

## Model MS-IT-0350-L 13637

Item No.	Description	Position	Item No.	Description	Position	Item No.	Description	Position
15204	Housing for 13637	A1	34771	Clip for 13637	A39	34805	Set Screw for 13637	A76
34736	Screw for 13637	A2	34772	Bearing for 13637	A40	34806	Cam Plate for 13637	A77
34737	Stop Plate for 13637	A3	15206	Bearing Spacer for 13637	A41	34807	Screw for 13637	A78
34738	Strain Relief for 13637	A4	34773	Bearing and Shaft for 13637	A42	34808	Screw TC for 13637	A79
34739	Set Screw for 13637	A5	34774	Belt TB2-380x12 for 13637	A43	34809	Index Knob for 13637	A80
34740	Bushing for 13637	A6	34775	Spindle Pulley for 13637	A44	34810	White Bushing for 13637	A81
34741	Set Screw for 13637	A7	34776	Set Screw for 13637	A45	34811	Copper Rivet for 13637	A82
15205	Tie Rod for 13637	A8	13599	Blade 350x57x4x280 for 13637	A46	34812	Meat Deflector for 13637	A83
34742	Nut for 13637	A9	34778	Screw TPSV for 13637	A47	34813	Deflector Screw for 13637	A84
34743	Tie Rod Knob for 13637	A10	34779	Blade Shield for 13637	A48	34814	Screw Chrome for 13637	A85
34744	Foot for 13637	A11	34780	Thumb Screw for 13637	A49	21657	Carriage Rail for 13637	A86
34745	Sharpener Support Bracket for 13637	A12	34781	Meat Grip for 13637	A50	34815	Screw TC for 13637	A87
34746	Sharpener Tie Rod for 13637	A13	34782	Set Screw for 13637	A51	34816	Pin for 13637	A88
34747	Washer for 13637	A14	34783	Washer PVC for 13637	A52	21658	Bearing for 13637	A89
34748	Screw TE for 13637	A15	34784	Rubber Washer for 13637	A53	34817	Set Screw for 13637	A90
34749	Screw TC for 13637	A16	34785	Meat Grip Spring for 13637	A54	15209	Carriage Support for 13637	A91
34750	Washer for 13637	A17	34786	Meat Grip Handle Screw for 13637	A55	34818	Set Screw PVC for 13637	A92
34751	Sharpener Support Pin for 13637	A18	34787	Meat Grip Handle for 13637	A56	34819	Slide Bar Spring for 13637	A93
34752	Sharpener Screw for 13637	A19	34788	Meat Grip Support Shaft for 13637	A57	34820	Carriage Slide Bar for 13637	A94
34753	Screw TC for 13637	A20	34789	Meat Tray Adjustment Plate for 13637	A58	34821	Indicator Light for 13637	A95
34754	Washer for 13637	A21	34790	Set Screw for 13637	A59	34822	Switch - On / Off for 13637	A96
34755	Sharpener Pin for 13637	A22	34791	Set Screw for 13637	A60	34823	Screw TC for 13637	A97
33553	Finishing Stone for 13637	A23	37448	Meat Tray for 13637	A61	34824	Capacitor Bracket for 13637	A98
34757	Nut for 13637	A24	34792	Meat Tray Knob for 13637	A62	15210	Capacitor for 13637	A99
34758	Set Screw for 13637	A25	34793	Pin for 13637	A63	34825	Wing Nut for 13637	A100
34759	Sharpener Spring for 13637	A26	34794	Meat Tray Support Arm for 13637	A64	34826	Motor Bracket for 13637	A101
34760	Ball Bearing for 13637	A27	34795	Carriage Knob for 13637	A65	34827	Screw for 13637	A102
34761	Screw for 13637	A28	15207	Carriage Handle for 13637	A66	34828	Motor for 13637	A103
34762	Sharpener Push Button for 13637	A29	34796	Nut for 13637	A67	31235	Adjustment Rod for 13637	A104
34763	Washer for 13637	A30	34797	Guide Plate for 13637	A68	34829	Washer for 13637	A105
34764	Screw TC for 13637	A31	34798	Guide Plate Support for 13637	A69	34830	Hinge for 13637	A106
34765	Sharpener Body for 13637	A32	34799	Screw TE for 13637	A70	34831	Motor Support Shaft for 13637	A107
34766	Sharpener Pin for 13637	A33	34800	Wavy Washer for 13637	A71	14859	Power Cord for 13637	A109
33032	45x9x6 Sharpening Stone for 13637	A34	34801	Cam for 13637	A72	37449	Bottom Cover for 13637	C4
34768	Sharpener Cover for 13637	A35	34802	Set Screw - Capped for 13637	A73	15211	Complete Pulley Assy. for 13637	
34769	Small Bushing for 13637	A37	15208	Guide Plate Pin for 13637	A74	34804	Complete Cam Assembly for 13637	
34770	Clip for 13637	A38	34803	Cam Guide for 13637	A75	15212	Complete Sharpening Assy. for 13637	

# Electrical Schematics

**Model MS-IT-0330-L** 13635

**Model MS-IT-0350-L** 13637

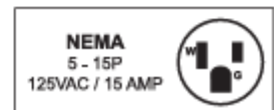
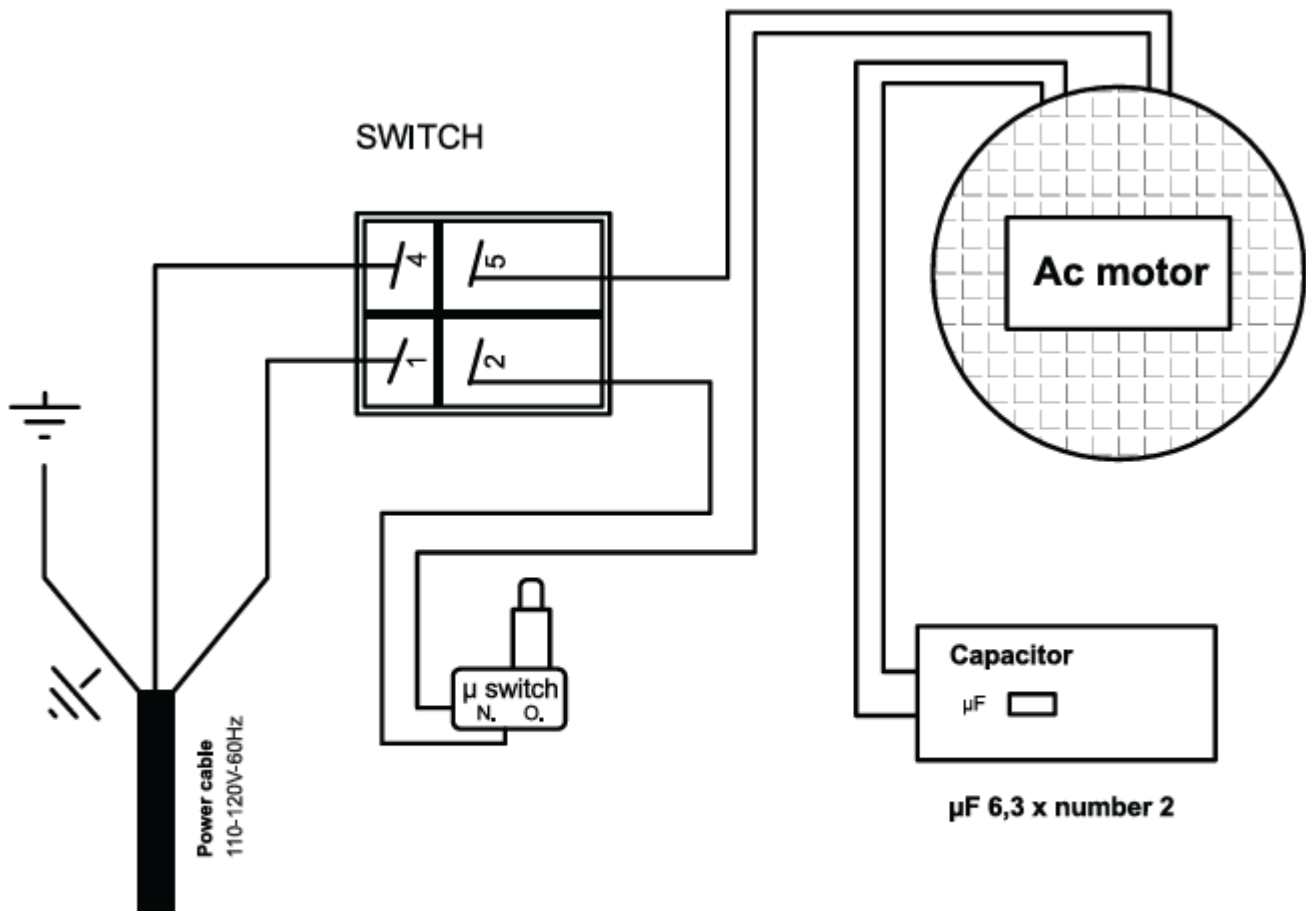



# Warranty Registration

Thank you for purchasing an Trento product. To register your warranty for this product, complete the information below, tear off the card at the perforation and then send to the address specified below. You can also register online by visiting:

Merci d'avoir acheté un produit Trento. Pour enregistrer votre garantie pour ce produit, complétez les informations ci-dessous, détachez la carte au niveau de la perforation, puis l'envoyer à l'adresse spécifiée ci-dessous. Vous pouvez également vous inscrire en ligne en visitant:

Gracias por comprar un producto Trento usted. Para registrar su garantía para este producto, complete la información a continuación, cortar la tarjeta en la perforación y luego enviarlo a la dirección indicada a continuación. También puede registrarse en línea en:

***<https://omcan.com/warranty-registration/>***

**For mailing in Canada**

**Pour postale au Canada**

**Por correo en Canadá**

**TRENTO**

PRODUCT WARRANTY REGISTRATION

3115 Pepper Mill Court,  
Mississauga, Ontario  
Canada, L5L 4X5

**For mailing in the US**

**Pour diffusion aux États-Unis**

**Por correo en los EE.UU.**

**TRENTO**

PRODUCT WARRANTY REGISTRATION

4450 Witmer Industrial Estates, Unit 4,  
Niagara Falls, New York  
USA, 14305

***or email to: [trentoservice@trentoequipment.com](mailto:trentoservice@trentoequipment.com)***



Purchaser's Information

Name: \_\_\_\_\_ Company Name: \_\_\_\_\_

Address: \_\_\_\_\_ Telephone: \_\_\_\_\_

City: \_\_\_\_\_ Province or State: \_\_\_\_\_ Postal or Zip: \_\_\_\_\_ Email Address: \_\_\_\_\_

Country: \_\_\_\_\_ Type of Company: \_\_\_\_\_

Restaurant  Bakery  Deli

Butcher  Supermarket  Caterer

Dealer from which Purchased: \_\_\_\_\_  Institution (*specify*): \_\_\_\_\_

Dealer City: \_\_\_\_\_ Dealer Province or State: \_\_\_\_\_  Other (*specify*): \_\_\_\_\_

Invoice: \_\_\_\_\_

Model Name: \_\_\_\_\_ Model Number: \_\_\_\_\_ Serial Number: \_\_\_\_\_

Machine Description: \_\_\_\_\_

Date of Purchase (MM/DD/YYYY): \_\_\_\_\_ Date of Installation (MM/DD/YYYY): \_\_\_\_\_

Would you like to extend the warranty?  Yes  No

**Thank you for choosing Trento | Merci d'avoir choisi Trento | Gracias por elegir Trento**

# TRENTO

ELEVATING CULINARY EXCELLENCE

TRENTO IS A SIGNATURE LINE OF PROFESSIONAL RESTAURANT EQUIPMENT FROM OMCAN OFFERING PREMIUM EUROPEAN BRANDS TO THE NORTH AMERICAN MARKET.

Thank you for your purchase!

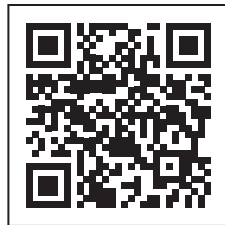

Follow us on social media  
@trentoequipment

